



# PCO2 - Quality Incident Protection

## PCO2-400 to PCO2-4800

User Guide

 Original Language

aerospace  
climate control  
electromechanical  
**filtration**  
fluid & gas handling  
hydraulics  
pneumatics  
process control  
sealing & shielding



ENGINEERING YOUR SUCCESS.

# ONLY USE PARKER GENUINE PARTS



**Warning**

The use of Parker genuine parts is essential in maintaining product performance and failure to do so may result in:

- Increased contamination in process streams
- Spoilage and potential recall
- Audit failure
- Invalidate warranty
- Manufacturing Downtime

Parker cannot provide support for non-original manufactured parts used with our PCO<sub>2</sub> systems and is not responsible for loss of revenue or quality concerns resulting from non-compliance.

---

<b>1</b>	<b>Safety Information</b>	<b>1</b>
1.1	Markings and Symbols	1
<b>2</b>	<b>Description</b>	<b>2</b>
2.1	Stages of Purification	2
2.2	Technical Specification	2
2.2.1	Pressure Correction Factors	2
2.3	Weights and Dimensions	3
2.4	Receiving and Inspecting the Equipment	4
2.4.1	Storage	4
2.4.2	Unpacking	4
2.4.3	Overview of the Equipment	5
<b>3</b>	<b>Installation &amp; Commissioning</b>	<b>6</b>
3.1	Recommended system layout	6
3.2	Locating the Equipment	7
3.2.1	Space Requirements	7
3.3	Mechanical Installation	7
3.3.1	General Requirements	7
3.3.2	Securing the Unit	7
<b>4</b>	<b>Operating the Equipment</b>	<b>8</b>
4.1	Starting the Equipment	8
<b>5</b>	<b>Servicing</b>	<b>9</b>
5.1	Cleaning	9
5.2	Service Intervals	9
5.3	Preventative Maintenance Kits	10
5.4	Maintenance Procedures	11
5.4.1	Cartridge Replacement Procedure (PCO2-400 Models Only)	11
5.4.2	OIL-X Element Change Procedure	13
5.4.3	Cartridge Replacement Procedure (PCO2-800 to PCO2-4800 Models)	14
5.4.4	IP50 Element Change Procedure	16
<b>6</b>	<b>Troubleshooting</b>	<b>17</b>

---

# 1 Safety Information

**Do not operate this equipment until the safety information and instructions in this user guide have been read and understood by all personnel concerned.**

## USER RESPONSIBILITY

FAILURE OR IMPROPER SELECTION OR IMPROPER USE OF THE PRODUCTS DESCRIBED HEREIN OR RELATED ITEMS CAN CAUSE DEATH, PERSONAL INJURY AND PROPERTY DAMAGE.

This document and other information from Parker Hannifin Corporation, its subsidiaries and authorised distributors provide product or system options for further investigation by users having technical expertise.

The user, through its own analysis and testing, is solely responsible for making the final selection of the system and components and assuring that all performance, endurance, maintenance, safety and warning requirements of the application are met. The user must analyse all aspects of the application, follow applicable industry standards, and follow the information concerning the product in the current product catalogue and in any other materials provided from Parker or its subsidiaries or authorised distributors.

To the extent that Parker or its subsidiaries or authorised distributors provide component or system options based upon data or specifications provided by the user, the user is responsible for determining that such data and specifications are suitable and sufficient for all applications and reasonably foreseeable uses of the components or systems.

Only competent personnel trained, qualified, and approved by Parker Hannifin should perform installation, commissioning, service and repair procedures.

With the exception of oxygen, any gas can cause asphyxiation in high enough concentrations. Always ensure that the unit is operated in a well ventilated area and all of the vent ports on the rear of the unit are kept clear and free from blockages.

Use of the equipment in a manner not specified within this user guide may result in an unplanned release of pressure, which may cause serious personal injury or damage.

When handling, installing or operating this equipment, personnel must employ safe engineering practices and observe all related regulations, health & safety procedures, and legal requirements for safety.

Ensure that the equipment is depressurised prior to carrying out any of the scheduled maintenance instructions specified within this user guide.

Parker Hannifin can not anticipate every possible circumstance which may represent a potential hazard. The warnings in this manual cover the most known potential hazards, but by definition can not be all-inclusive. If the user employs an operating procedure, item of equipment or a method of working which is not specifically recommended by Parker Hannifin the user must ensure that the equipment will not be damaged or become hazardous to persons or property.

Most accidents that occur during the operation and maintenance of machinery are the result of failure to observe basic safety rules and procedures. Accidents can be avoided by recognising that any machinery is potentially hazardous.

Should you require an extended warranty, tailored service contracts or training on this equipment, or any other equipment within the Parker Hannifin range, please contact your local Parker Hannifin office.

Details of your nearest Parker Hannifin sales office can be found at [www.parker.com/gsf](http://www.parker.com/gsf)





Retain this user guide for future reference.

### Related Documents:

- Preventative Maintenance Guide 176070002
- 12 Month Service Instructions 176070003

## 1.1 Markings and Symbols

The following markings and international symbols are used on the equipment or within this manual:

	Caution, Read the User manual.		When disposing of old parts always follow local waste disposal regulations.
 Warning	Highlights actions or procedures which, if not performed correctly, may lead to personal injury or death.		Conformité Européenne
 Caution	Highlights actions or procedures which, if not performed correctly, may lead to damage to this product.		

## 2 Description

The Parker domnick hunter PCO<sub>2</sub> systems offer a comprehensive solution to preserve and guarantee the quality of gaseous carbon dioxide used in sparkling beverage bottling.

Operating as a Quality Incident Protection system against potential carbon dioxide impurities, the system guarantees the gas quality so it remains within industry and company guidelines, preventing detrimental consequences to the finished end beverage, producers reputation and their bottom-line.

PCO<sub>2</sub> is the beverage industry preferred choice and is installed in over 150 countries worldwide.

### 2.1 Stages of Purification

<b>Stage 1</b> 0.01 micron particle filtration Removal of non-volatile organic residue (NVOR) and other contaminants down to 0.01 ppm
<b>Stage 2</b> Removal of water vapour and partial removal of hydrocarbons
<b>Stage 3</b> Primary removal of aromatic hydrocarbons (Benzene, Toulene etc and Acetaldehyde)
<b>Stage 4</b> Removal of sulphur compounds (COS, H <sub>2</sub> S, DMS etc)
<b>Stage 5</b> 0.01 micron particle filtration
<b>Stage 6*</b> Point of use VBACE sterile gas membrane. Hi Flow Tetpor II

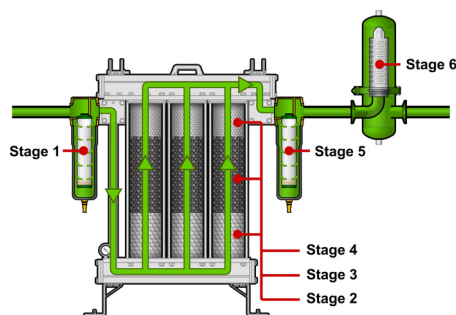

\* Optional - Sterilising Grade: consult Parker for operational use.

### 2.2 Technical Specification

This specification is valid when the equipment is located, installed, operated, and maintained as specified within this user guide.

Stated flow rates are at 24.1 bar g (350 psi g).

Parameter	Units	PCO <sub>2</sub> 400	PCO <sub>2</sub> 800	PCO <sub>2</sub> 1600	PCO <sub>2</sub> 2400	PCO <sub>2</sub> 3200	PCO <sub>2</sub> 4000	PCO <sub>2</sub> 4800	PCO <sub>2</sub> 3200 (Duplex)*	PCO <sub>2</sub> 4000 (Duplex)*	PCO <sub>2</sub> 4800 (Duplex)*	
<b>Technical Data</b>												
Minimum Operating Pressure	bar g (psi g)	3.0 (43.5)	3.0 (43.5)	3.0 (43.5)	3.0 (43.5)	3.0 (43.5)	3.0 (43.5)	3.0 (43.5)	3.0 (43.5)	3.0 (43.5)	3.0 (43.5)	
Maximum Operating Pressure	bar g (psi g)	20.7 (300)	24.1 (350)	24.1 (350)	24.1 (350)	24.1 (350)	24.1 (350)	24.1 (350)	24.1 (350)	24.1 (350)	24.1 (350)	
Minimum Operating Temperature	°C (°F)	-20 (-4)	-20 (-4)	-20 (-4)	-20 (-4)	-20 (-4)	-20 (-4)	-20 (-4)	-20 (-4)	-20 (-4)	-20 (-4)	
Maximum Operating Temperature	°C (°F)	40 (104)	40 (104)	40 (104)	40 (104)	40 (104)	40 (104)	40 (104)	40 (104)	40 (104)	40 (104)	
Inlet CO <sub>2</sub> Quality	ISBT beverage grade CO <sub>2</sub>											
<b>Flowrate</b>												
	Kg / hr	181	363	726	1089	1451	1814	2177	2903	3628	4354	
	Lb / hr	400	800	1600	2400	3200	4000	4800	6400	8000	9600	
<b>Port Connections</b>												
CO <sub>2</sub> Inlet	in	1" NPT						1-1/2" NPT				
CO <sub>2</sub> Outlet	in	1" NPT						1-1/2" NPT				

\*Systems are installed in duplex / parallel to double the flow rate.

All systems are supplied as NPT with stainless steel adapters 'NPT to BSP' as standard.

PCO<sub>2</sub> CO<sub>2</sub> systems are for gaseous CO<sub>2</sub> only.

For flows at other pressures, apply the correction factors shown below.

#### 2.2.1 Pressure Correction Factors

Inlet Pressure	bar g	3	4	5	6	7	8	9	10	11	12	13
	psi g	44	58	73	87	102	116	130	145	160	174	189
Correction Factor		0.19	0.23	0.28	0.33	0.38	0.42	0.47	0.52	0.57	0.61	0.66
Inlet Pressure	bar g	14	15	16	17	18	19	20	21	22	23	24
	psi g	203	218	232	247	261	275	290	304	319	333	350
Correction Factor		0.71	0.76	0.80	0.85	0.90	0.95	1	1	1	1	1

## 2.3 Weights and Dimensions

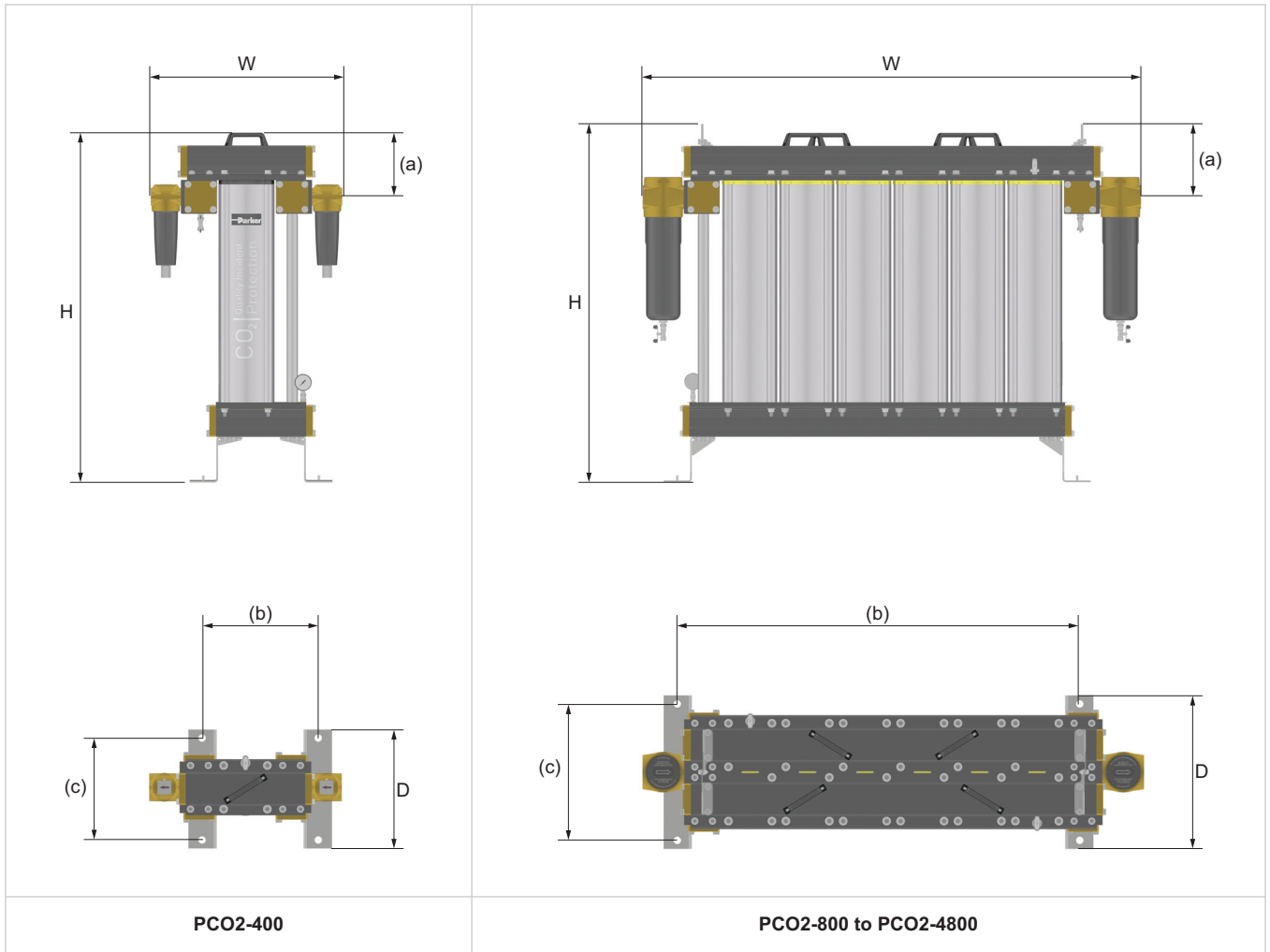

Model	Height (H)		Width (W)		Depth (D)		(a)		(b)		(c)		Clearance*		Weight	
	mm	ins	mm	ins	mm	ins	mm	ins	mm	ins	mm	ins	mm	ins	kg	lbs
PCO2-400	1035	40.75	564	22.20	350	13.78	189.5	7.5	340	13.4	300	11.81	680	26.8	75	165
PCO2-800	1061	41.77	632	24.88	450	17.72	215.5	8.5	340	13.4	400	15.75	680	26.8	84	185
PCO2-1600	1061	41.77	801	31.54	450	17.72	215.5	8.5	509	20.04	400	15.75	680	26.8	128	282
PCO2-2400	1061	41.77	970	38.19	450	17.72	215.5	8.5	678	26.70	400	15.75	680	26.8	172	379
PCO2-3200	1061	41.77	1139	44.84	450	17.72	215.5	8.5	847	33.35	400	15.75	680	26.8	217	478
PCO2-4000	1061	41.77	1308	51.50	450	17.72	215.5	8.5	1016	40.0	400	15.75	680	26.8	260	573
PCO2-4800	1061	41.77	1477	58.15	450	17.72	215.5	8.5	1185	46.7	400	15.75	680	26.8	304	670

\*Clearance required for the removal and servicing of the cartridges.

---

## 2.4 Receiving and Inspecting the Equipment

On receipt of the equipment carefully inspect the packaging for damage. If the packaging is damaged inform the delivery company immediately and contact your local Parker Hannifin office.

### 2.4.1 Storage

If the equipment is to be stored prior to installation, do not remove it from the packaging. Ensure that it is stored in an upright position as indicated by the arrows on the packaging.



**Do not attempt to lift the equipment by yourself. It is recommended that the equipment be carried by a minimum of two persons or transported on a pallet truck.**

**Note.** The storage area should be secure and the environmental conditions should fall within those specified in the technical specification. If the equipment is stored in an area where the environmental conditions fall outside of those specified, it is essential that it be moved to its final location (installation site) and left to stabilise prior to unpacking. Failure to do this could cause condensing humidity and potential failure of the equipment.

### 2.4.2 Unpacking

Remove the lid and all four sides of the packing crate. Carefully move the unit to its final location using a forklift truck or pallet truck. Once in its final location, remove the unit from the pallet via the 4x bolts.

**Note:** Suitable slings and an overhead crane maybe required depending on the product size.

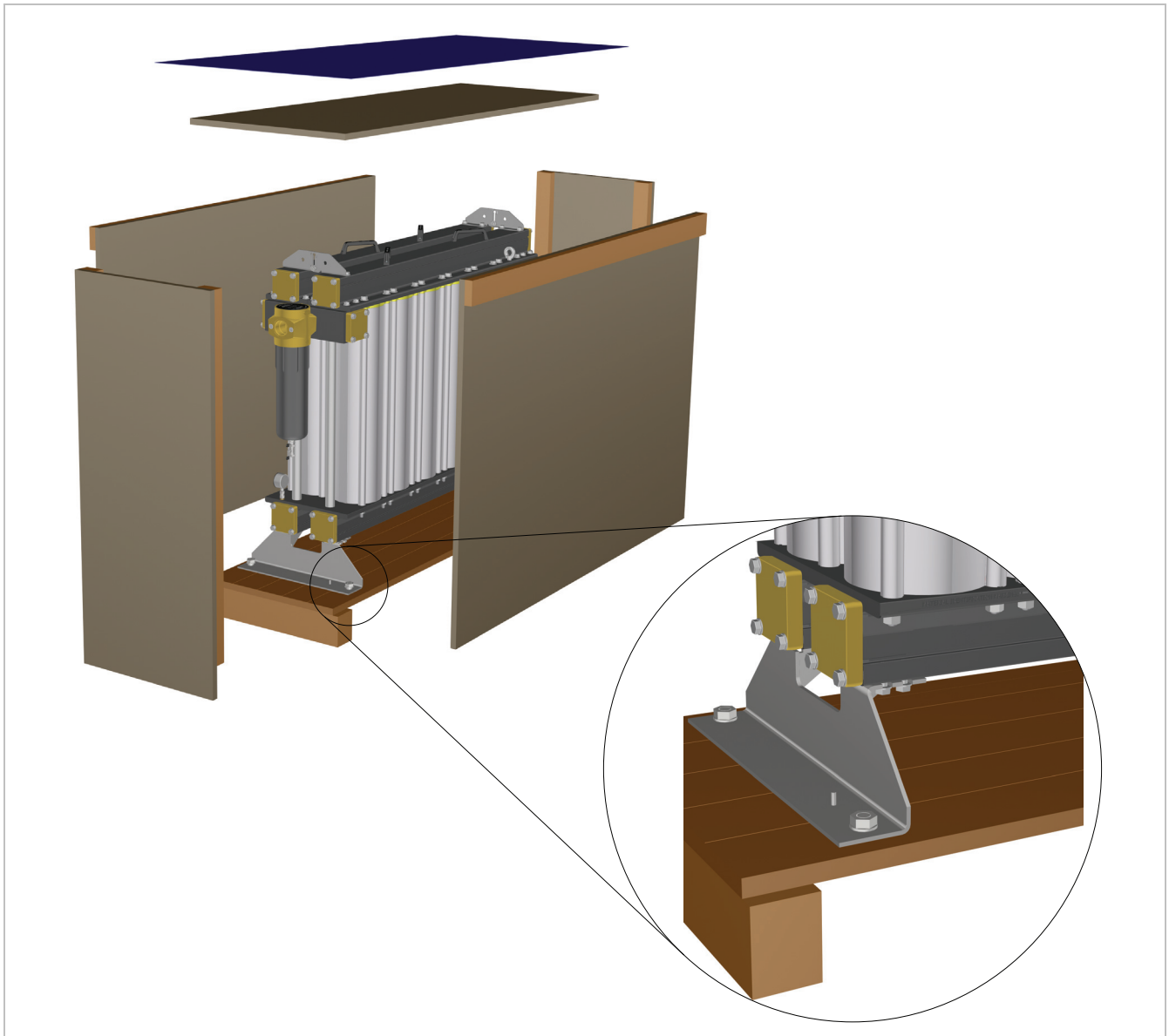

### 2.4.3 Overview of the Equipment

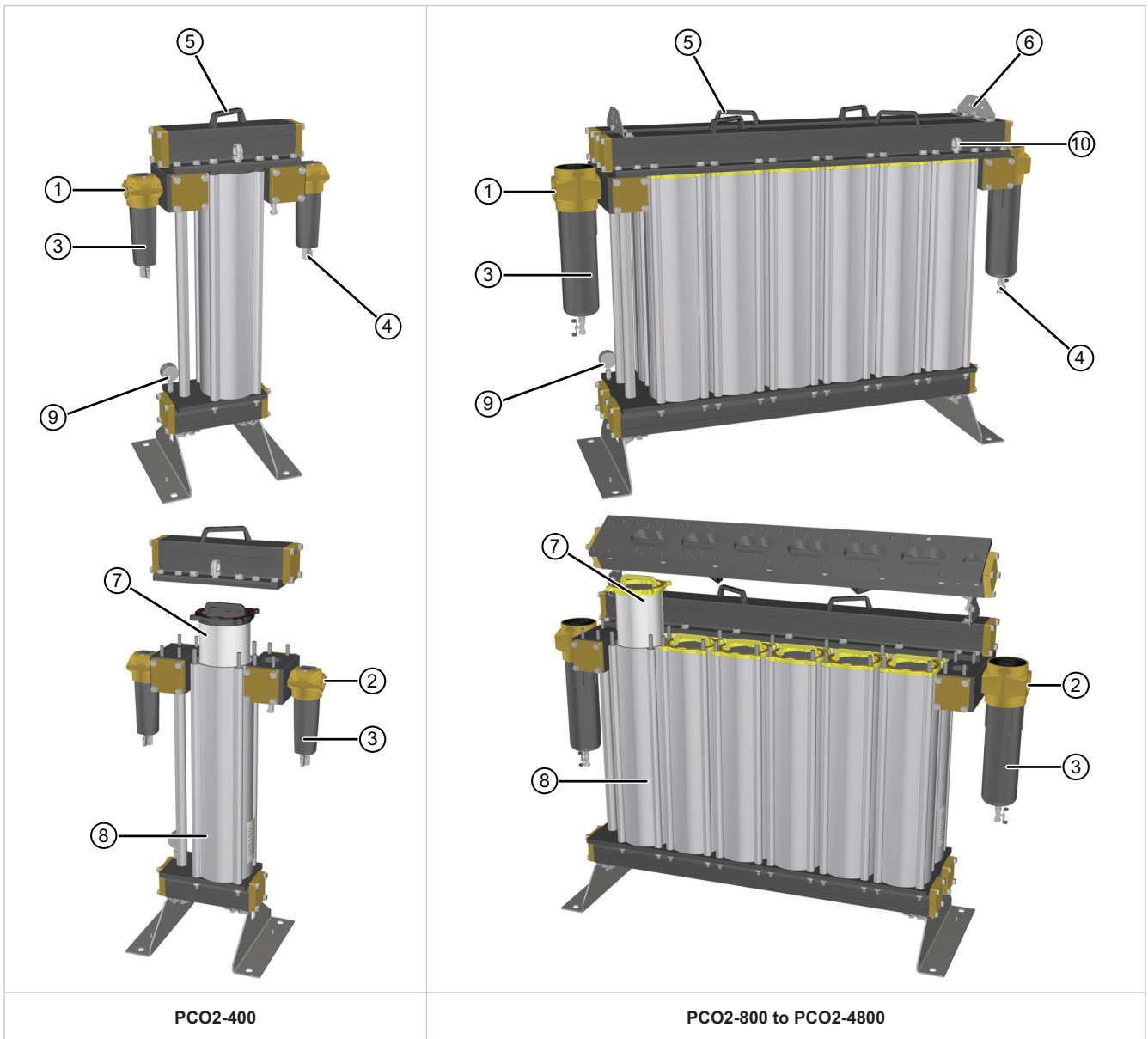

**Key:**

Item	Description
1	System Inlet
2	System Outlet
3	AA020P OIL-X Filter (PCO2-400 Models only) IP50-AA-0465GPCO2 Filter
4	Manual Filter Drain
5	Manifold Lifting Handle
6	Manifold Hinge (PCO2-800 to PCO2-4800 Models)
7	Desiccant Cartridge
8	PCO2 Column
9	Pressure Gauge
10	Lifting Eye Bolt



### 3 Installation & Commissioning



Only competent personnel trained, qualified, and approved by Parker Hannifin should perform commissioning and service procedures.

#### 3.1 Recommended system layout

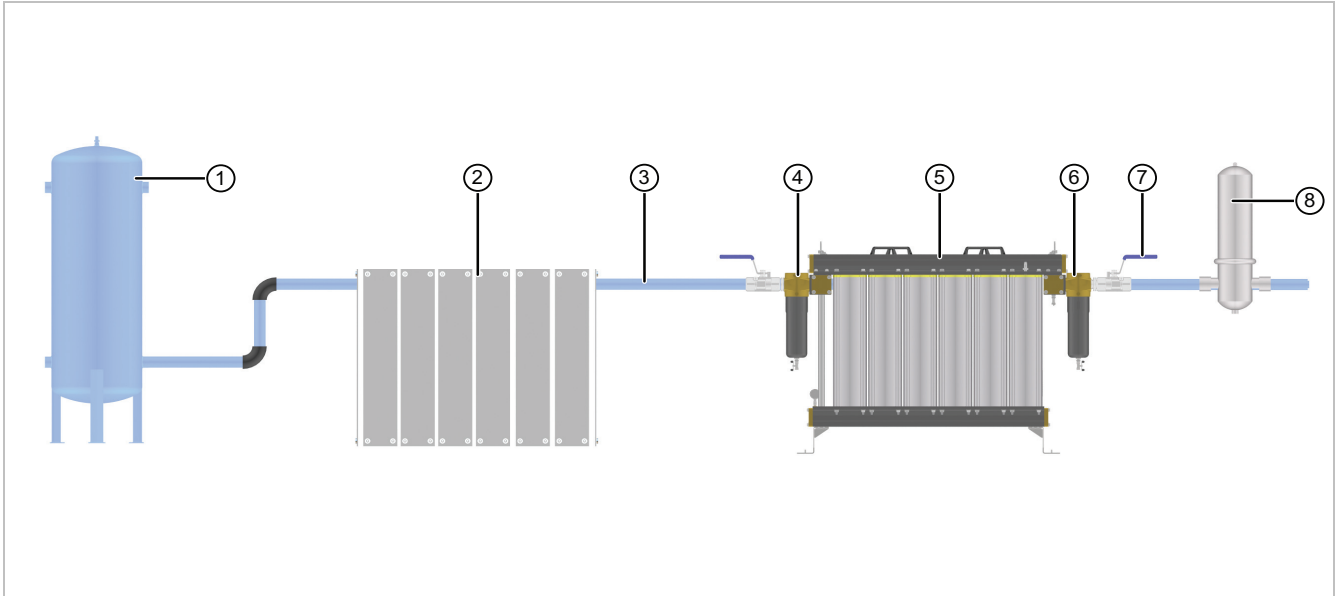

1	Liquid CO2 storage tank
2	Vaporiser
3	Stainless steel piping
4	Pre filtration - Stage One
5	PCO2 Unit
6	Post filtration - Stage five
7	Isolation valves
8	Sterile Filter (Optional)

## 3.2 Locating the Equipment

### 3.2.1 Space Requirements

The equipment should be mounted on a flat surface capable of supporting its own weight plus the weight of all ancillary parts. The minimum footprint requirements are specified below, however there must be adequate space around the equipment to allow airflow and access for maintenance purposes and lifting equipment. A minimum spacing of approximately 500mm (20 ins) is recommended around all sides of the unit and 750mm (30 ins) above it.

**Do Not position the equipment so that it is difficult to operate.**

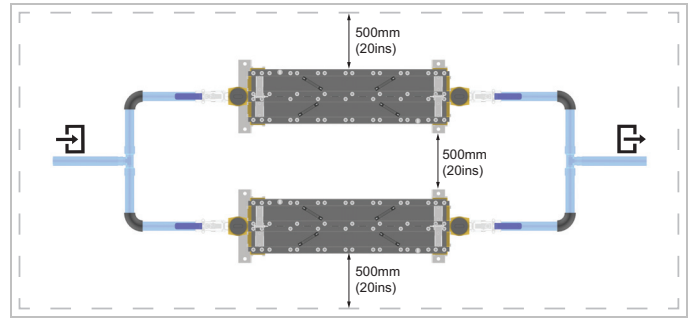

## 3.3 Mechanical Installation

### 3.3.1 General Requirements

Ensure that all piping materials are suitably rated for the application, clean and debris free. The diameter of the pipes must be sufficient to allow unrestricted inlet air supply to the equipment.

Apply approximately 8 - 12 turns of P.T.F.E tape to the high quality stainless steel piping.

Fit the piping along with the relevant pre and post filtration onto the inlet and outlet. Isolation valves must be installed before the inlet filtration and after the outlet filtration.

When routing pipes ensure that they are adequately supported to prevent damage or leaks in the system.

All components used within the system must be rated to at least the maximum operating pressure of the equipment. It is recommended that the system is protected with suitably rated pressure relief valves.

### 3.3.2 Securing the Unit

Mounting holes are provided in the feet of the unit. Once the unit has been positioned in its final location ensure that it is securely fixed in place.

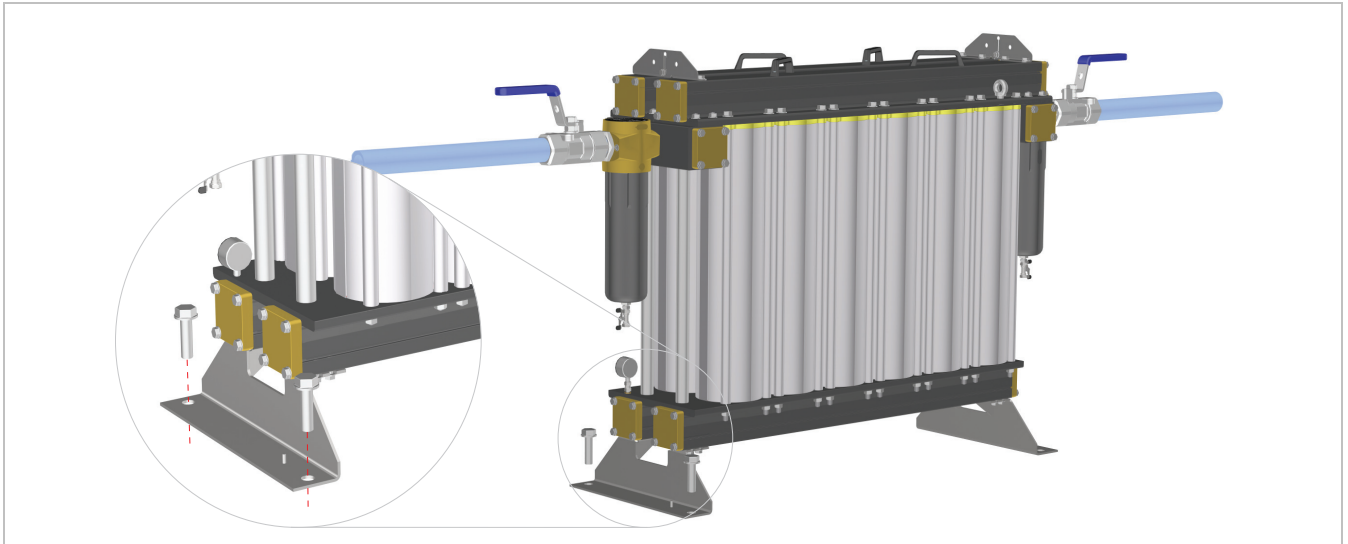

---

## 4 Operating the Equipment

### 4.1 Starting the Equipment

**Note:** On start-Up it is normal for the outlet temperature to increase for a limited period of time.

- 1 Open the inlet valve slowly to gradually pressurise the PCO2 unit.
- 2 Open the outlet valve slowly to re-pressurise the downstream piping.



Do not open the inlet or outlet valves rapidly or subject the PCO2 unit to excessive pressure differential as damage may occur.

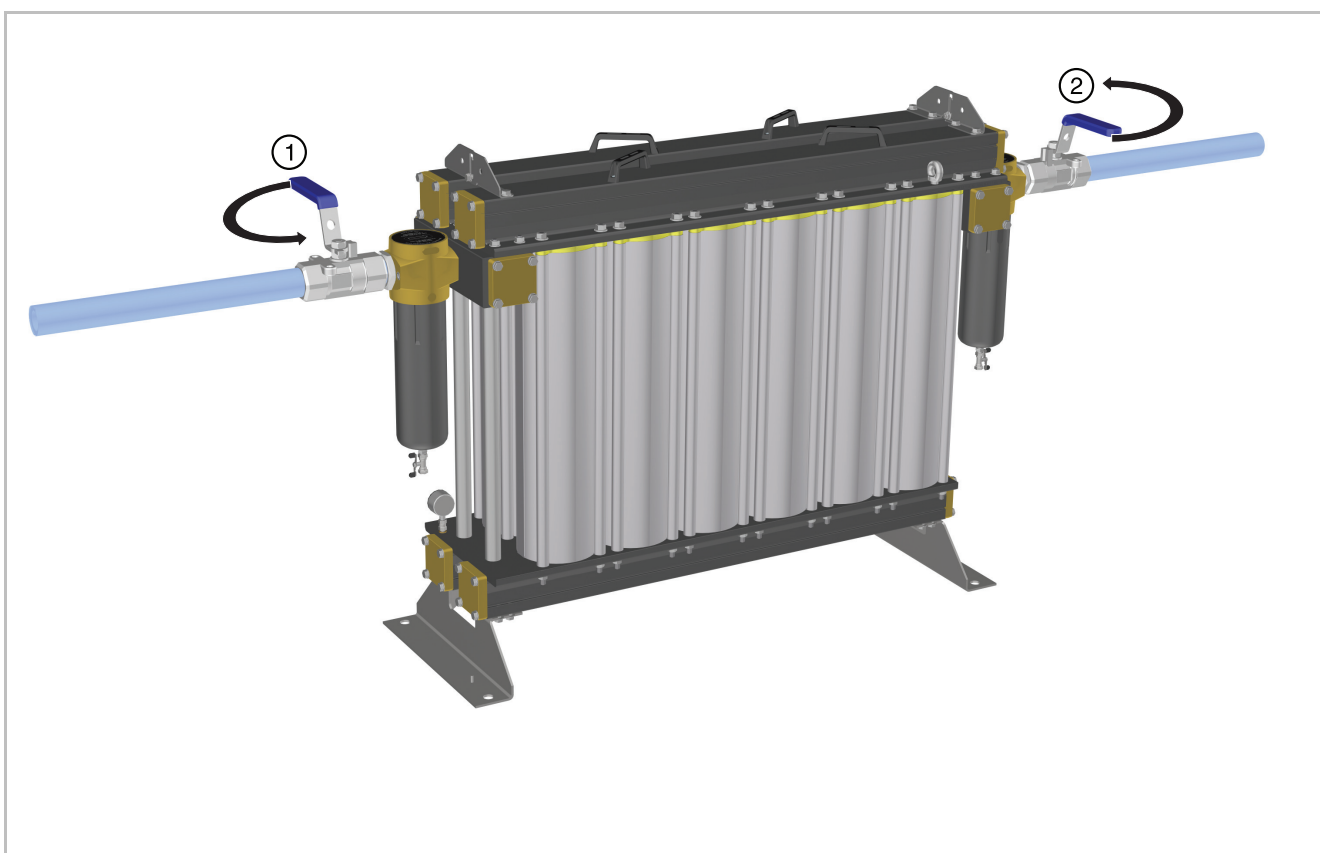









## 5 Servicing

### 5.1 Cleaning

Clean the equipment with a damp cloth only. If required you may use a mild detergent, however do not use abrasives or solvents as they may damage the warning labels on the equipment.

### 5.2 Service Intervals

Component	Operation	Weekly	12 Months
System	Check for leaks.		
PCO2	Check the pressure gauge.		
Filters	Drain filter bowl		
System	<b>Recommended Service A</b> Replace the filter elements and the mixed bed adsorption cartridges		
PCO2	Inspect the columns and manifolds (internal and external)		
Filters	Inspect the filter housings (internal and external).		

Service	12 Months	24 Months	36 Months	48 Months	60 Months	72 Months
A						

Key:

	Check		Preventative Maintenance
---	-------	---	--------------------------

Parker recommend that the adsorbent cartridges and filter elements are exchanged within the recommended 12-month period or before the recorded cumulative mass of the unit has been exceeded or after a quality incident has occurred, whichever comes first. Please refer to the below table for the maximum mass flow of each model.

PCO2 Model Number	Max Operating Pressure Bar/PSI	Flow kg/hr @ Max Operating Pressure	Max Mass over 12 Months: kg	Flow lb/hr @ Max Operating Pressure	Max Mass over 12 Months: lb	Max Mass over 12 Months: Tonne (Metric Ton)
PCO2-400	20 Barg / 300 PSIG	181	1581216	400	3494400	1581
PCO2-800	24 Barg / 350 PSIG	363	3171168	800	6988800	3170
PCO2-1600	24 Barg / 350 PSIG	726	6342336	1600	13977600	6340
PCO2-2400	24 Barg / 350 PSIG	1089	9513504	2400	20966400	9510
PCO2-3200	24 Barg / 350 PSIG	1451	12675936	3200	27955200	12680
PCO2-4000	24 Barg / 350 PSIG	1814	15847104	4000	34944000	15850
PCO2-4800	24 Barg / 350 PSIG	2177	19018272	4800	41932800	19020
PCO2-3200 (Duplex)	24 Barg / 350 PSIG	2903	25360608	6400	55910400	25361
PCO2-4000 (Duplex)	24 Barg / 350 PSIG	3628	31694208	8000	69888000	31701
PCO2-4800 (Duplex)	24 Barg / 350 PSIG	4354	38036544	9600	83865600	38041

### 5.3 Preventative Maintenance Kits

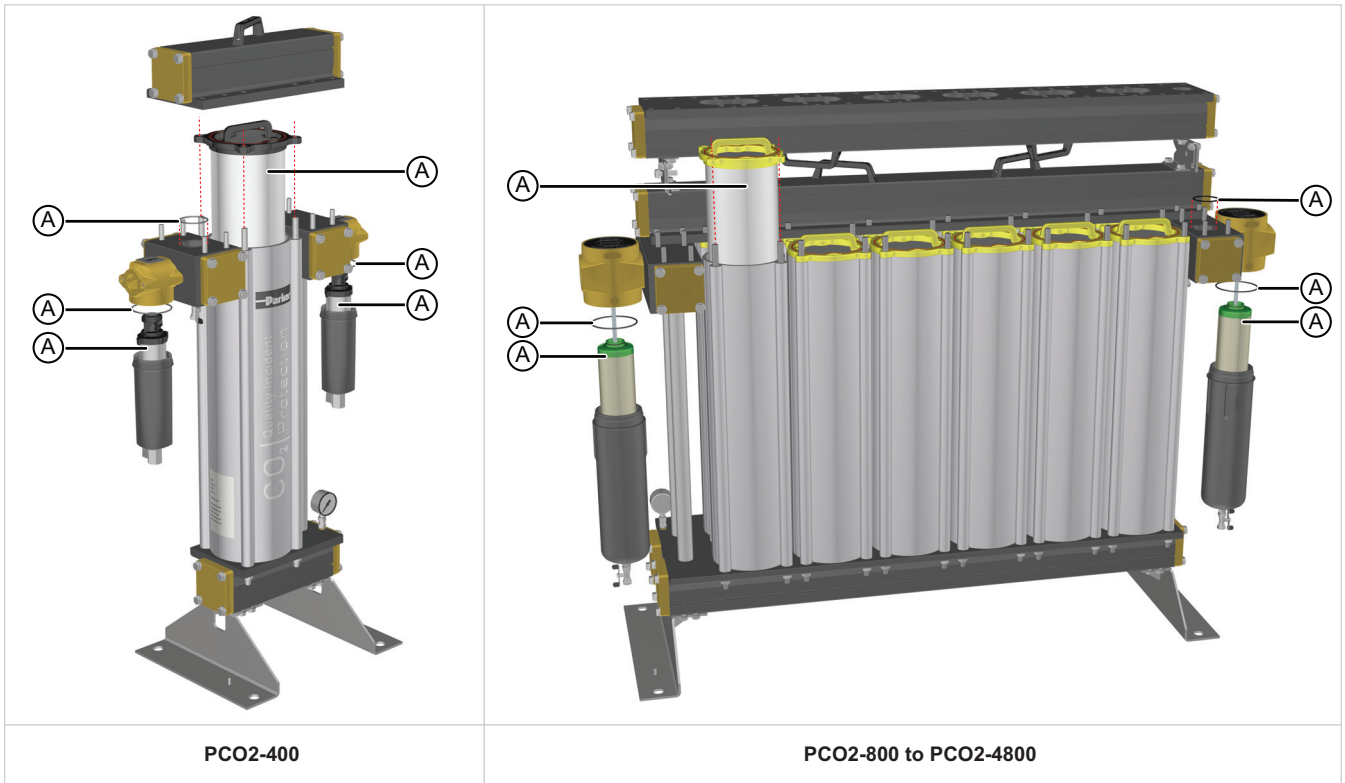

PCO2-400

PCO2-800 to PCO2-4800

#### Required every 8000Hrs (12 months)



With OIL-X filter elements  
(PCO2-400 Models only)



With OIL-X IP50 filter elements  
(PCO2-800 to PCO2-4800)

Model	PM Kit Number	Kit Contents	Order Quantity
PCO2 400	MK-PCO2-400	1x Desiccant cartridges 2x Outlet block o-rings 2x P020AA Filter element 2x Filter bowl o-rings	1
PCO2 800	MK-PCO2-800	2x Desiccant cartridges 2x Outlet block o-rings 2x IP50-AA Filter element 2x Filter bowl o-rings	1
PCO2 1600	MK-PCO2-1600	4x Desiccant cartridges 2x Outlet block o-rings 2x IP50-AA Filter element 2x Filter bowl o-rings	1
PCO2 2400	MK-PCO2-2400	6x Desiccant cartridges 2x Outlet block o-rings 2x IP50-AA Filter element 2x Filter bowl o-rings	1
PCO2 3200	MK-PCO2-3200	8x Desiccant cartridges 2x Outlet block o-rings 2x IP50-AA Filter element 2x Filter bowl o-rings	1
PCO2 4000	MK-PCO2-4000	10x Desiccant cartridges 2x Outlet block o-rings 2x IP50-AA Filter element 2x Filter bowl o-rings	1
PCO2 4800	MK-PCO2-4800	12x Desiccant cartridges 2x Outlet block o-rings 2x IP50-AA Filter element 2x Filter bowl o-rings	1
PCO2 3200 (Duplex)	MK-PCO2-6400	16x Desiccant cartridges 4x Outlet block o-rings 4x IP50-AA Filter element 4x Filter bowl o-rings	1
PCO2 4000 (Duplex)	MK-PCO2-8000	20x Desiccant cartridges 4x Outlet block o-rings 4x IP50-AA Filter element 4x Filter bowl o-rings	1
PCO2 4800 (Duplex)	MK-PCO2-9600	24x Desiccant cartridges 4x Outlet block o-rings 4x IP50-AA Filter element 4x Filter bowl o-rings	1

## 5.4 Maintenance Procedures

### 5.4.1 Cartridge Replacement Procedure (PCO2-400 Models Only)



Ensure that the system is fully depressurised before carrying out the below maintenance procedures.

- A Remove the M12 nuts from one side of the manifold.
- B Using the handle, carefully lift and remove the manifold from the unit and store in a safe place.



Ensure that the inlet and outlet piping is adequately supported before removing the manifold from the unit.

- C Remove the old desiccant cartridges and dispose in accordance with local regulations.
- D Remove the o-ring from the outlet manifold block and replace with the one provided within the 12 month Preventative Maintenance kits.  
**Note: Apply a light coating of Molykote III grease to the o-rings.**
- E Insert the replacement desiccant cartridges into the columns.
- F Refit the manifold and secure the M12 nuts in sequence, starting with the centre nuts and working outwards. The nuts should be secured in two stages. **Stage 1: 27Nm (20 ft.lb) and Stage 2: 40Nm (30 ft.lb).**

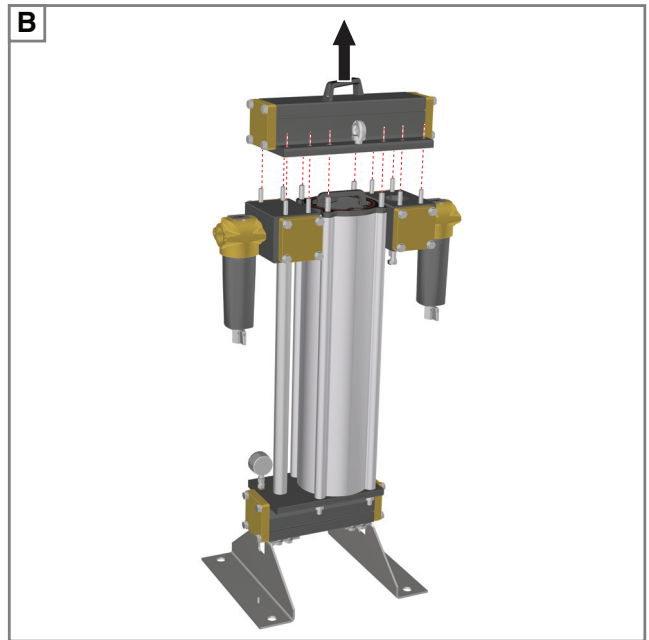
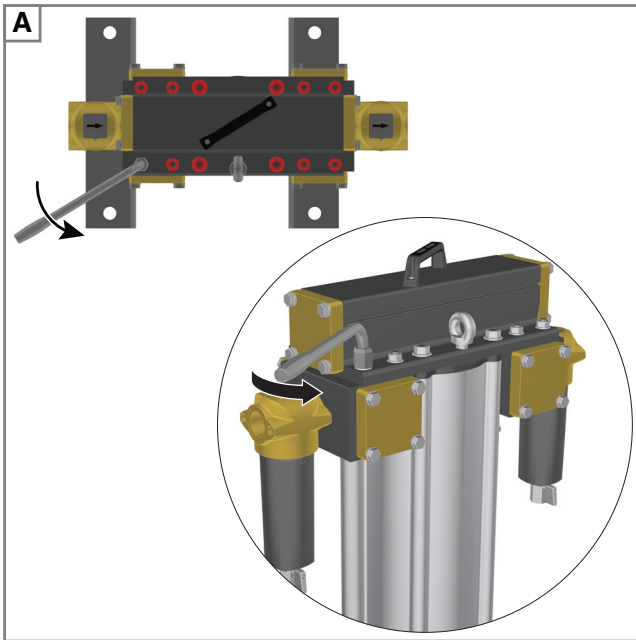

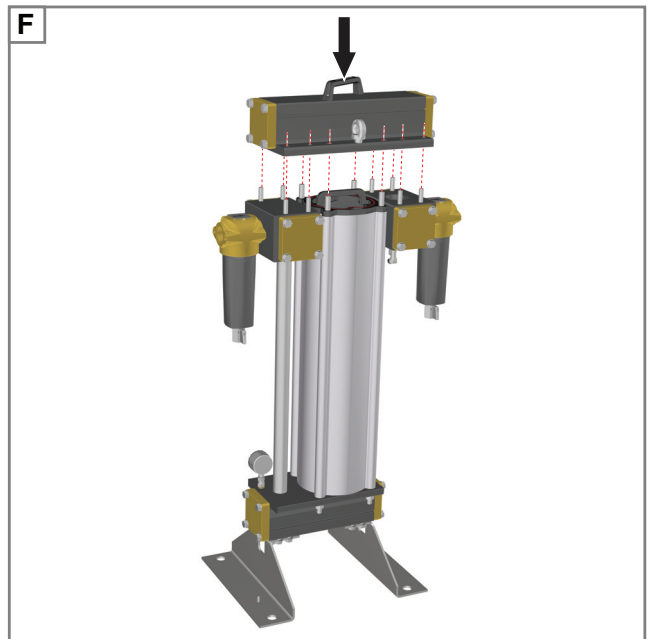
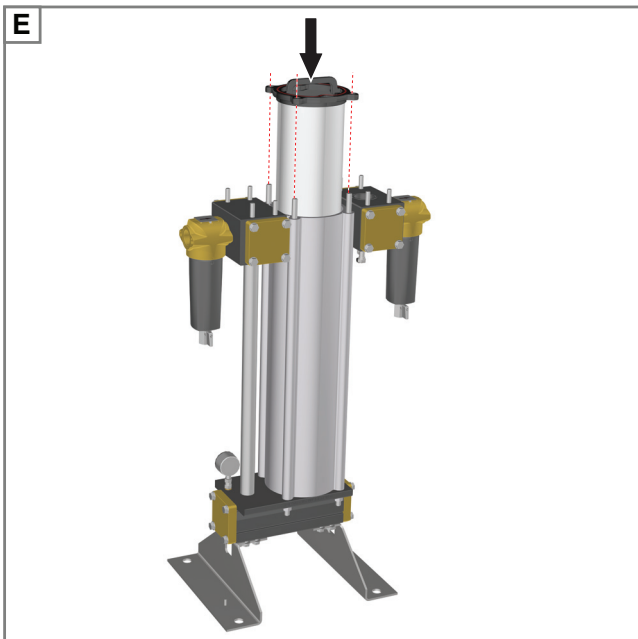
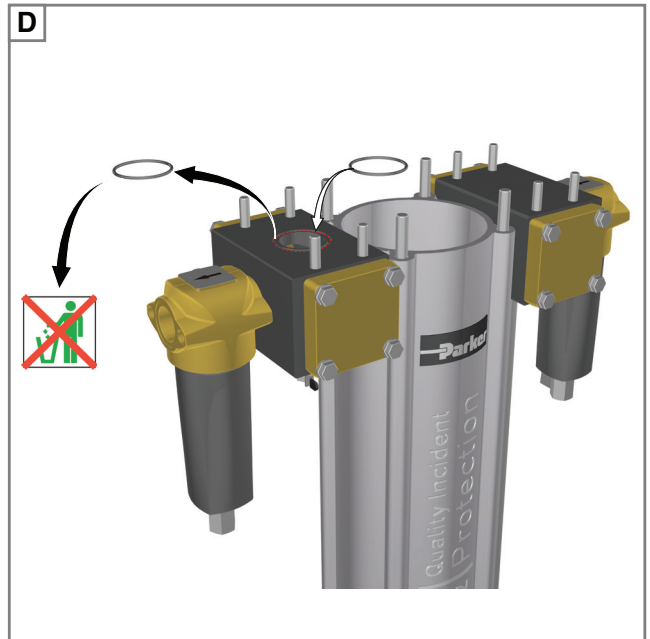
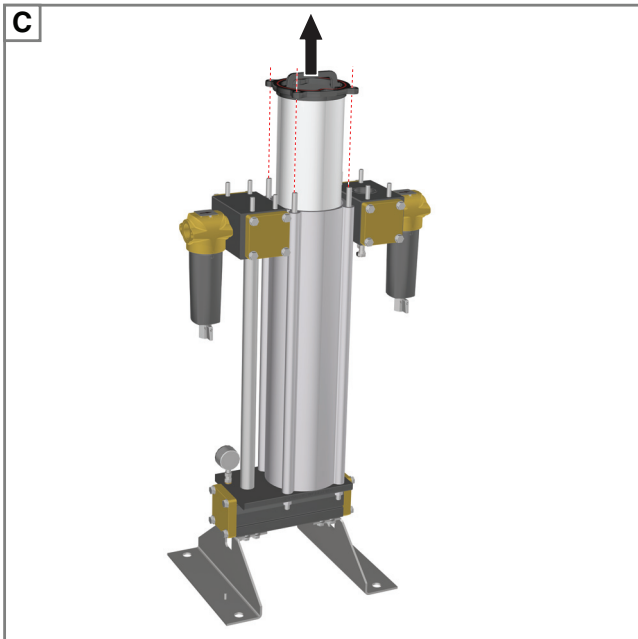

## 5.4.2 OIL-X Element Change Procedure

- A Ensure that the filters are fully depressurised by opening the manual drain.
- B Unscrew the filter bowl and remove the used element.



Warning

We recommend the use of gloves when touching contaminated elements.

- C Replace the o-ring located on the filter bowl with the new one provided within the 12 month Preventative Maintenance kits.



Caution

Ensure to lubricate the o-ring and threads with Molykote III grease.

- D Insert the new element into the filter bowl ensuring that the lugs are correctly seated in the grooves.
- E Refit the filter bowl to the head ensuring that the threads are fully engaged and the locking details are aligned.
- F Close the manual drain and re-pressurise the system.

Item	Description	Item	Description
1	Filter head	4	Filter bowl o-ring
2	Filter bowl	5	Manual Drain
3	Element		

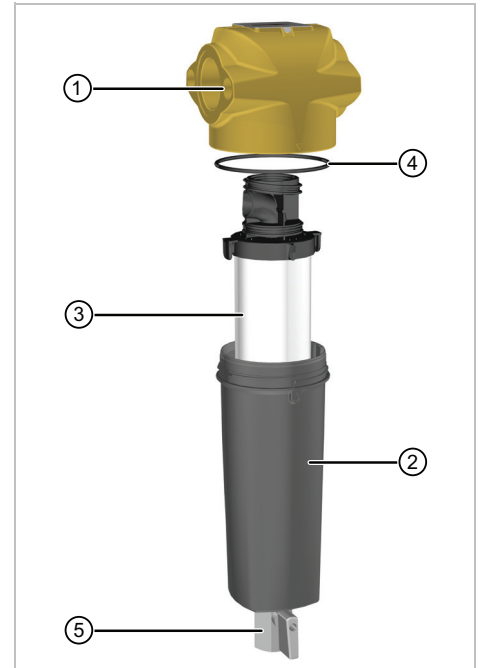



### 5.4.3 Cartridge Replacement Procedure (PCO2-800 to PCO2-4800 Models)

The top manifold has been split into two sections in order to simplify the removal of the desiccant cartridges.



Ensure that the system is fully depressurised before carrying out the below maintenance procedures.

- A Remove the M12 nuts from one side of the manifold.
- B Using the handles, carefully lift the manifold until the M8 hex bolt has travelled to the top of the manifold hinge. Gently pull the manifold towards yourself until it has locked into position.
- C Carefully rotate the manifold 180° as shown. Once opened, place an M10 locking bolt through the holes in the two halves of the hinges to prevent the manifold falling onto the operator during service.



Take care not to trap fingers/hands on the handles when rotating the manifold.

- D Remove the old desiccant cartridges and dispose in accordance with local regulations.  
**Note: The cartridges should only be lifted using the handles and directly upwards to prevent clashing with the hinged manifold.**
- E Remove the o-ring from the outlet manifold block and replace with the one provided within the 12 month Preventative Maintenance kits.  
**Note: Apply a light coating of Molykote III grease to the o-rings.**
- F Insert the replacement desiccant cartridges into the columns.

Refit the manifold and secure the M12 nuts in sequence, starting with the centre nuts and working outwards. The nuts should be secured in two stages. **Stage 1: 27Nm (20 ft.lb)** and **Stage 2: 40Nm (30 ft.lb)**.

Replace the desiccant cartridges on the opposite side following the same procedure as above.

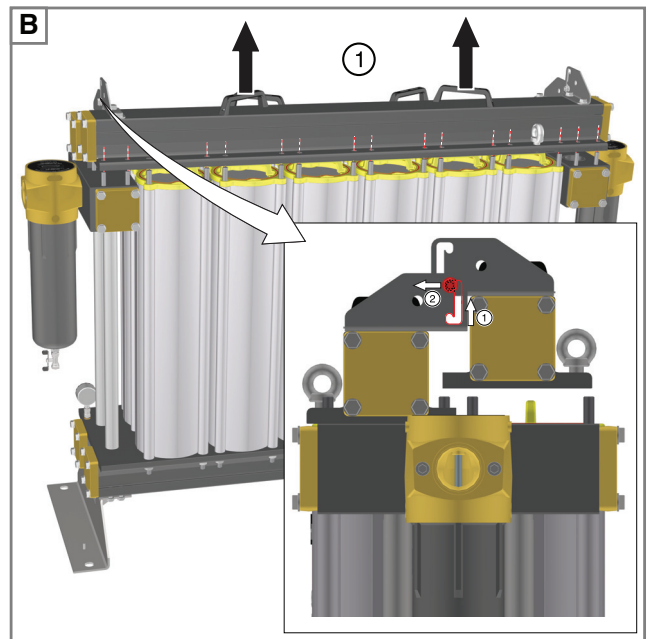
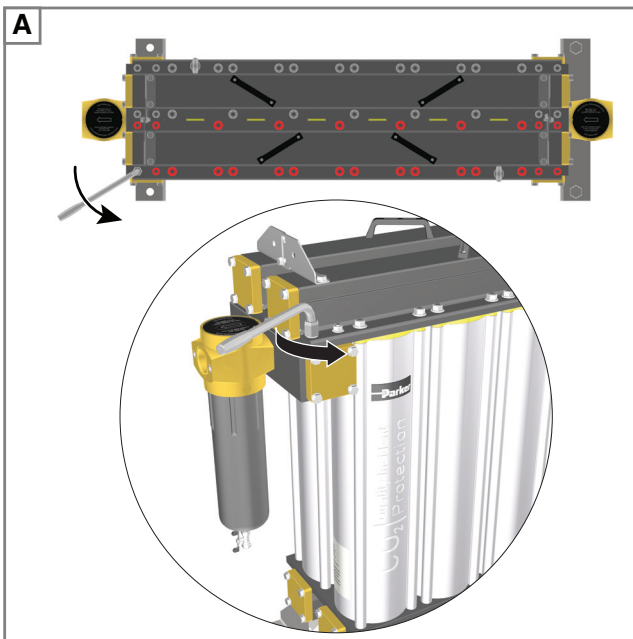

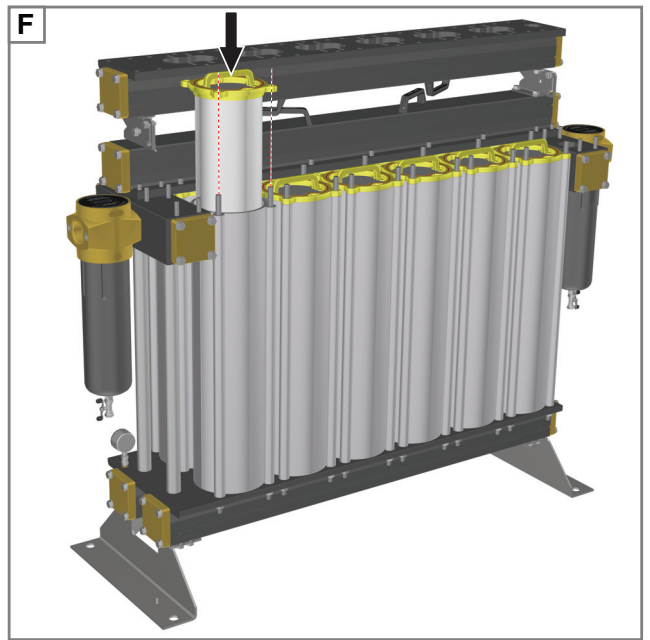
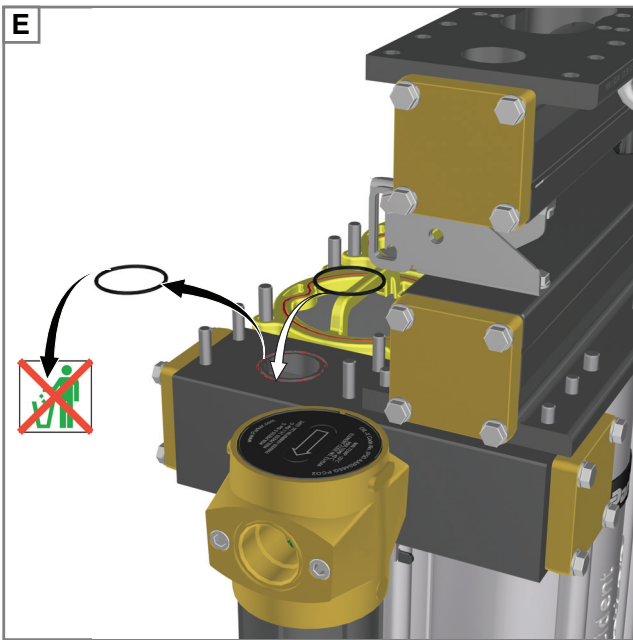
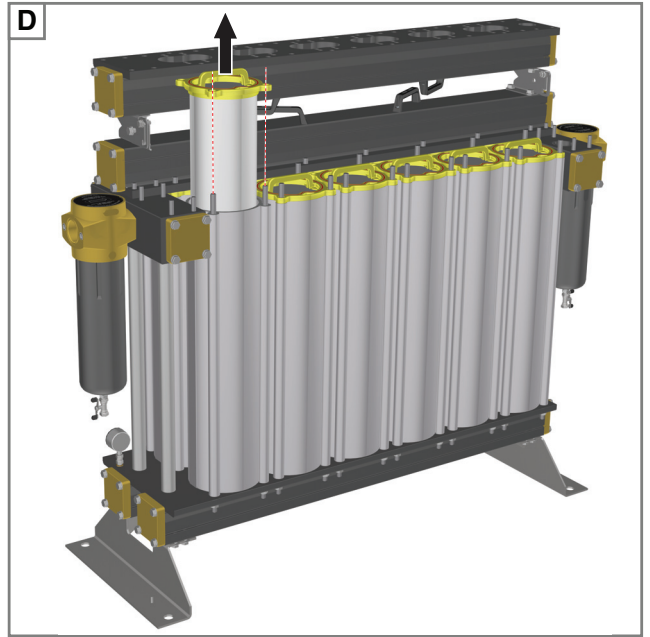
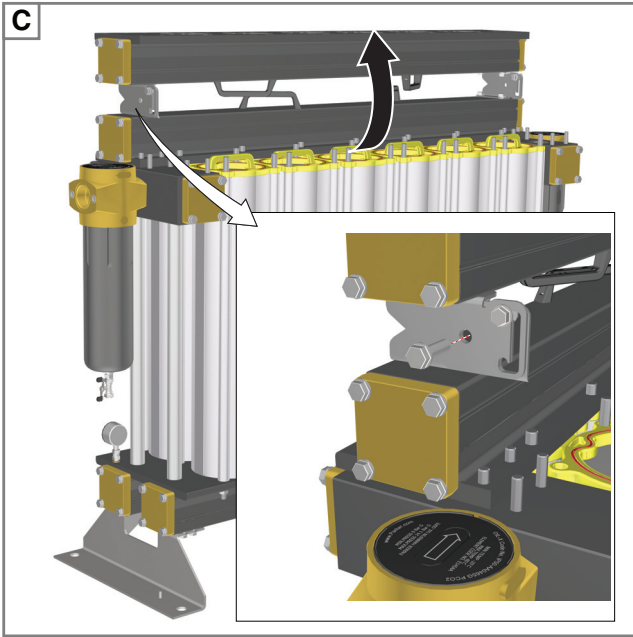

### 5.4.4 IP50 Element Change Procedure

- A Ensure that the filters are fully depressurised by opening the 1/4" BSPT ball valves.
- B Unscrew the filter bowl and then the used element from the tie rod.

 **Warning** We recommend the use of gloves when touching contaminated elements.

- C Replace the o-ring located on the filter bowl with the new one provided within the 12 month Preventative Maintenance kits.

 **Caution** Ensure to lubricate the o-ring and threads with Molykote III grease.

- D Fit the new element onto the tie rod and tighten.
- E Refit the filter bowl to the head ensuring that the threads are fully engaged.
- F Close the 1/4" BSPT ball valves and re-pressurise the system.

Item	Description	Item	Description
1	Filter head	4	Element
2	Filter bowl	5	Filter bowl o-ring
3	Tie rod	6	1/4" BSPT ball valve

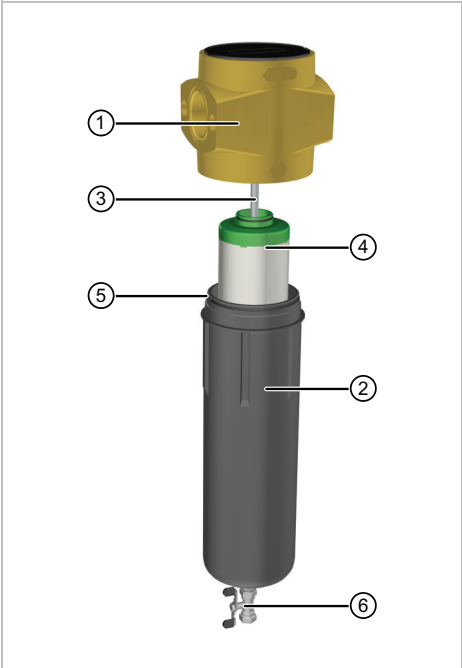

## 6 Troubleshooting

Problem	Indication	Possible Cause	Action Required
Poor dewpoint	Condensed water downstream of the system	Bulk water carried over into the PCO2 unit	Check pre-filtration elements and drains
		Overflow of the PCO2 unit	Compare flow through the PCO2 unit to rated flow
			Check for modifications to the compressed air system
		Inlet pressure too low	Check functioning of the compressor
		Inlet temperature too high	Check functioning of the compressor
Check ventilation around the dryer			
High pressure drop through filter / system package	Pressure gauges fitted to compressor / train	Blocked filters	Replace any blocked filters
		Overflow of the PCO2 unit	Eliminate conditions leading to over flow
Outlet air flow stops	Indicated downstream pressure drops to zero	Compressor failure	Investigate problem with the compressor and correct

# EU Declaration of Conformity

EN

Parker Hannifin Manufacturing Limited GSFE  
Dukesway, Team Valley Trading Estate, Gateshead, Tyne & Wear, NE11 0PZ, UK  
PCO2 Carbon Dioxide Quality Incident Protection System

PCO2-400, PCO2-800, PCO2-1600, PCO2-2400, PCO2-3200, PCO2-4000, PCO2-4800

	PED	2014/68/EU
	-	-
<b>Directives</b>	-	-
	-	-
	-	-
	-	-
	-	-
	PED	Generally in accordance with ASME VIII Div 1:2017 and AS1210:2010
<b>Standards used</b>	-	-
	-	-
	-	-
	-	-
	-	-
<b>PED Assessment Route:</b>	B + D	
<b>EC Type-examination Certificate:</b>	COV0912556/1	
<b>Notified body for PED:</b>	Lloyd's Register Verification 71 Fenchurch Street, London, EC3M 4BS	
<b>Notified Body for ATEX:</b>	-	
	- -	
<b>Authorised Representative</b>	Steven Rohan Division Engineering Manager, Parker Hannifin Manufacturing Limited GSFE	

## Declaration

This declaration of conformity issued under the sole responsibility of the manufacturer.

Signature:



**Date:** 29 April 2019

**Declaration Number:**  
00308 / 29.4.19

# Parker Worldwide

## Europe, Middle East, Africa

**AE – United Arab Emirates,** Dubai  
Tel: +971 4 8127100  
parker.me@parker.com

**AT – Austria,** Wiener Neustadt  
Tel: +43 (0)2622 23501-0  
parker.austria@parker.com

**AT – Eastern Europe,** Wiener Neustadt  
Tel: +43 (0)2622 23501 900  
parker.easteurope@parker.com

**AZ – Azerbaijan,** Baku  
Tel: +994 50 2233 458  
parker.azerbaijan@parker.com

**BE/LU – Belgium,** Nivelles  
Tel: +32 (0)67 280 900  
parker.belgium@parker.com

**BY – Belarus,** Minsk  
Tel: +375 17 209 9399  
parker.belarus@parker.com

**CH – Switzerland,** Etoy  
Tel: +41 (0)21 821 87 00  
parker.switzerland@parker.com

**CZ – Czech Republic,** Klecany  
Tel: +420 284 083 111  
parker.czechrepublic@parker.com

**DE – Germany,** Kaarst  
Tel: +49 (0)2131 4016 0  
parker.germany@parker.com

**DK – Denmark,** Ballerup  
Tel: +45 43 56 04 00  
parker.denmark@parker.com

**ES – Spain,** Madrid  
Tel: +34 902 330 001  
parker.spain@parker.com

**FI – Finland,** Vantaa  
Tel: +358 (0)20 753 2500  
parker.finland@parker.com

**FR – France,** Contamine s/Arve  
Tel: +33 (0)4 50 25 80 25  
parker.france@parker.com

**GR – Greece,** Athens  
Tel: +30 210 933 6450  
parker.greece@parker.com

**HU – Hungary,** Budapest  
Tel: +36 1 220 4155  
parker.hungary@parker.com

**IE – Ireland,** Dublin  
Tel: +353 (0)1 466 6370  
parker.ireland@parker.com

**IT – Italy,** Corsico (MI)  
Tel: +39 02 45 19 21  
parker.italy@parker.com

**KZ – Kazakhstan,** Almaty  
Tel: +7 7272 505 800  
parker.easteurope@parker.com

**NL – The Netherlands,** Oldenzaal  
Tel: +31 (0)541 585 000  
parker.nl@parker.com

**NO – Norway,** Asker  
Tel: +47 66 75 34 00  
parker.norway@parker.com

**PL – Poland,** Warsaw  
Tel: +48 (0)22 573 24 00  
parker.poland@parker.com

**PT – Portugal,** Leca da Palmeira  
Tel: +351 22 999 7360  
parker.portugal@parker.com

**RO – Romania,** Bucharest  
Tel: +40 21 252 1382  
parker.romania@parker.com

**RU – Russia,** Moscow  
Tel: +7 495 645-2156  
parker.russia@parker.com

**SE – Sweden,** Spånga  
Tel: +46 (0)8 59 79 50 00  
parker.sweden@parker.com

**SK – Slovakia,** Banská Bystrica  
Tel: +421 484 162 252  
parker.slovakia@parker.com

**SL – Slovenia,** Novo Mesto  
Tel: +386 7 337 6650  
parker.slovenia@parker.com

**TR – Turkey,** Istanbul  
Tel: +90 216 4997081  
parker.turkey@parker.com

**UA – Ukraine,** Kiev  
Tel: +380 44 494 2731  
parker.ukraine@parker.com

**UK – United Kingdom,** Warwick  
Tel: +44 (0)1926 317 878  
parker.uk@parker.com

**ZA – South Africa,** Kempton Park  
Tel: +27 (0)11 961 0700  
parker.southafrica@parker.com

## North America

**CA – Canada,** Milton, Ontario  
Tel: +1 905 693 3000

**US – USA,** Cleveland  
Tel: +1 216 896 3000

## Asia Pacific

**AU – Australia,** Castle Hill  
Tel: +61 (0)2-9634 7777

**CN – China,** Shanghai  
Tel: +86 21 2899 5000

**HK – Hong Kong**  
Tel: +852 2428 8008

**IN – India,** Mumbai  
Tel: +91 22 6513 7081-85

**JP – Japan,** Tokyo  
Tel: +81 (0)3 6408 3901

**KR – South Korea,** Seoul  
Tel: +82 2 559 0400

**MY – Malaysia,** Shah Alam  
Tel: +60 3 7849 0800

**NZ – New Zealand,** Mt Wellington  
Tel: +64 9 574 1744

**SG – Singapore**  
Tel: +65 6887 6300

**TH – Thailand,** Bangkok  
Tel: +662 186 7000-99

**TW – Taiwan,** Taipei  
Tel: +886 2 2298 8987

## South America

**AR – Argentina,** Buenos Aires  
Tel: +54 3327 44 4129

**BR – Brazil,** Sao Jose dos Campos  
Tel: +55 800 727 5374

**CL – Chile,** Santiago  
Tel: +56 2 623 1216

**MX – Mexico,** Apodaca  
Tel: +52 81 8156 6000

### European Product Information Centre

Free phone: 00 800 27 27 5374

(from AT, BE, CH, CZ, DE, DK, EE, ES, FI, FR, IE, IL, IS, IT, LU, MT, NL, NO, PL, PT, RU, SE, SK, UK, ZA)

